

General overview  
Smurfit Kappa  
Parenco



# Smurfit Kappa Parenco – Renkum NL

Sustainability is an essential and integral part of our business operations

We are a:

- ▶ Frontrunner in sustainability
- ▶ Responsible and attractive employer
- ▶ Reliable partner for all stakeholders



# History of the mill

100+ years of dedicated focus on packaging paper and graphic paper

|                      |   |  |   |  |   |  |  |  |
|----------------------|---|--|---|--|---|--|--|--|
| Corporate & Strategy | <b>1598</b><br>First paper mill ("The Bock") founded in Renkum, Netherlands | <b>1981</b><br>Bankruptcy of Van Gelder, factory continues under "Parenco"<br><br><b>1985</b><br>Start of Reparco operations | <b>1983</b><br>Haindl Paper acquired Parenco<br><br><b>1987</b><br>Reparco acquires Van Irsel | <b>1989</b><br>Reparco acquires businesses in Nijmegen and Randstad<br><br><b>1997</b><br>Reparco invests in new 22,000m <sup>2</sup> site in Nijmegen | <b>2001</b><br>Norske Skog acquires Parenco from Haindl Paper | <b>2006</b><br>Reorganisation and over €5m investment in Reparco | <b>2012-13</b><br>Acquisition of Parenco and Reparco by H2 Equity Partners<br><br>Reorganization and substantial improvement of profitability<br><br>Divestment of Reparco USA | <b>2017-18</b><br>Footprint optimization and investment in the new sorting line at the mill site<br><br>Divestment of Nijmegen in 2017 and The Hague in 2018 |
|----------------------|---|--|---|--|---|--|--|--|

FOUNDATION AND DEVELOPMENT OF BUSINESS

BECOMING A WORLDWIDE SUPPLIER

BUILDING A BETTER BUSINESS

|                  |   |   |   |   |  |   |  |  |
|------------------|---|---|---|---|--|---|--|--|
| Mill Development | <b>1912</b><br>Van Gelder & Zonen builds paper mill "Renkum 2" on the Rhine shore | <b>1979</b><br>Old paper mills of "Renkum 2" are replaced by one new paper mill (PM2) | <b>1987</b><br>Parenco builds second paper mill (PM1)<br><br><b>1989</b><br>PM2 is modernized | <b>2003-2004</b><br>Installation of incinerator (37 MWth) | <b>2009</b><br>Parenco idles PM2 and converts PM1 into a SC-B machine<br><br>All wood processing lines and one waste paper processing line are stopped | <b>2015</b><br>Installation of new sorting line at mill site (€5m)<br><br>Investment in fully automated warehouse (€3.5m) | <b>2015-17</b><br>Conversion of PM2 into a testliner and fluting machine (€88m)<br><br>Successful ramp-up of PM2 and entrance into containerboard market | <b>2018</b><br>Smurfit Kappa Group acquires Reparenco for €480m as of the 1 <sup>st</sup> of July. |
|------------------|---|---|---|---|--|---|--|--|

# Smurfit Kappa Parenco: 2 PM's

PM1 is a graphical (SC-B) paper machine - PM2 is a packaging paper machine



# Smurfit Kappa Parenco- Site lay out

Total site surface 40 hectares



Harbour for  
coasters upto  
1200 tons

Effluent  
plant and  
biogas

RCP sorting plant  
and storage for  
PM1

Utilities  
incl  
biomass

DIP Lines  
for PM1

Bale  
storage  
PM2

Pulp plant  
PM2

PM1

PM2

Warehouse  
incl AGVs

# Business model overview

Two production lines supplied for 100% with recovered paper

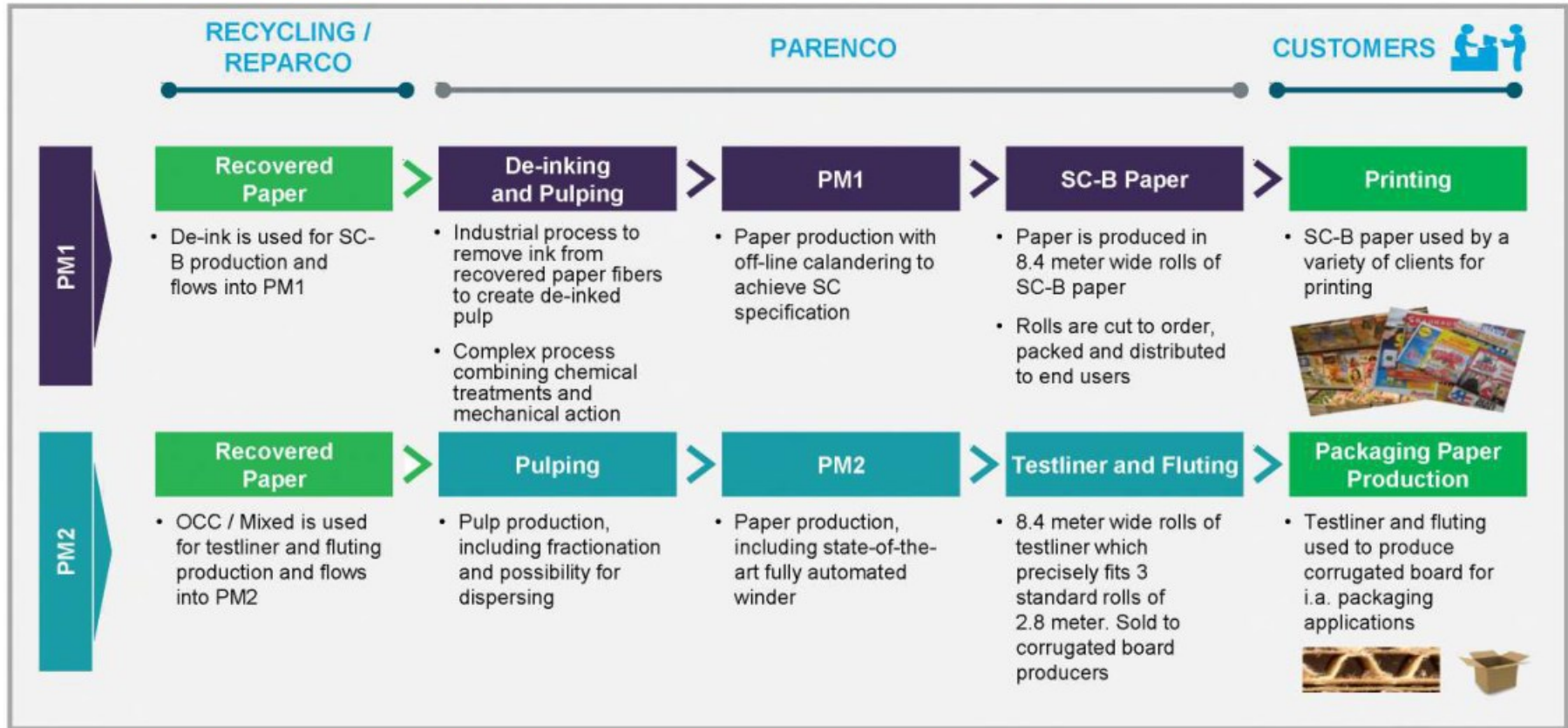

# SK Parenco's Main assets

PM1



PM2



# PM1 – graphical paper



Constructed in 1987, rebuild in 1998

Design speed: 1600 m/min

Trimmed width: 8,56 mm

Products: Super Calendared B (SCB)

Grammage: 45 - 56 g/m<sup>2</sup>

Capacity: 285,000 t/y



# PM2 – packaging paper

Build in 1979, rebuild in 2016

Design speed: 1200 m/min

Width : 8,65 m

Products: Fluting and Testliner

Grammage: 80 - 120 g/m<sup>2</sup>

Capacity: 400.000 t/year



# End products

Our product offering is broad and varied



# Sustainability

SK Parenco → circularity at its core

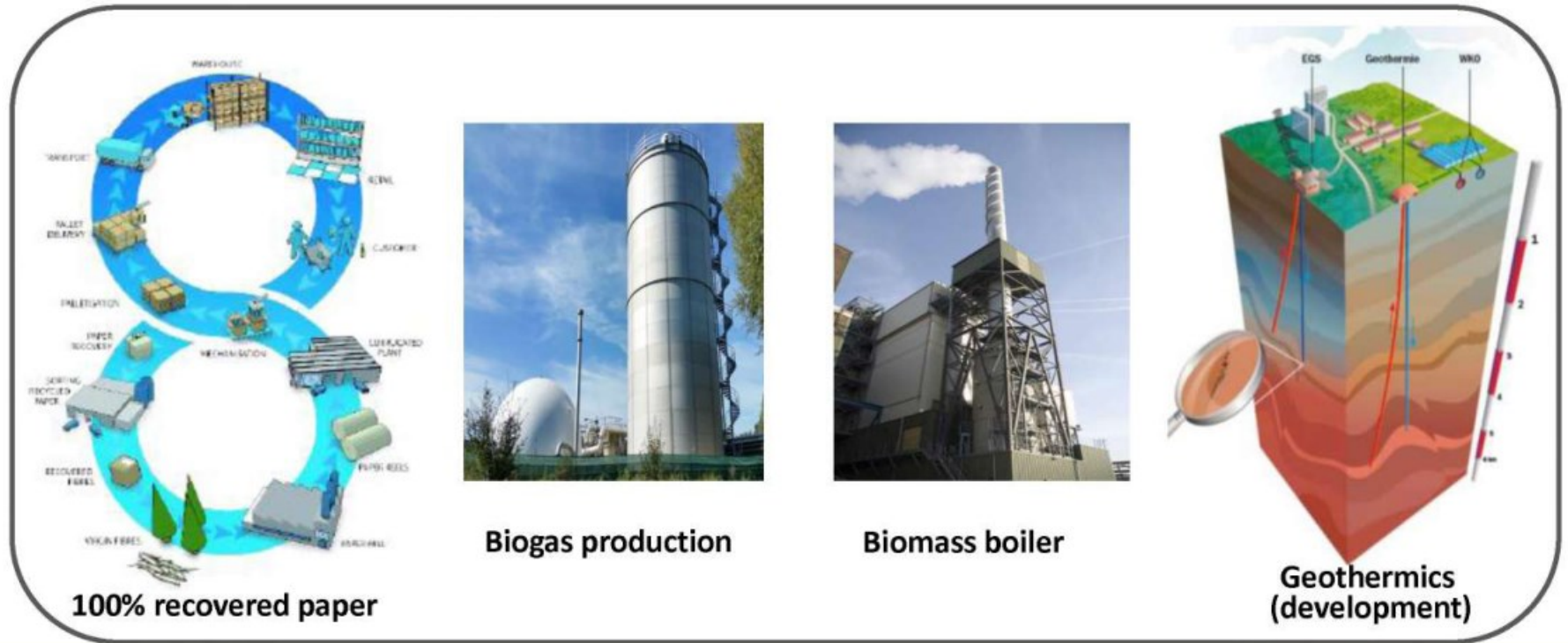

Biogas production



Biomass boiler

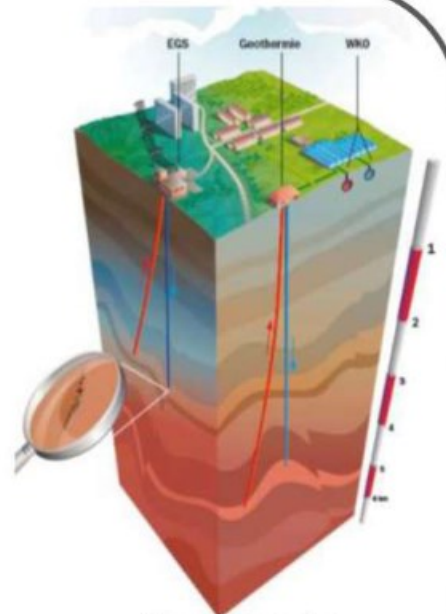

Geothermics (development)

# Simplified Flowsheets

- ▶ Flotatie-Ontinkting-Installatie (FOI)
- ▶ Papermachine 1
- ▶ ReCovered Fiber-installatie (RCF)
- ▶ Papermachine 2
- ▶ Centrale
- ▶ Afvalwaterzuiveringinstallatie

## FOI4 - Simplified Flowsheet

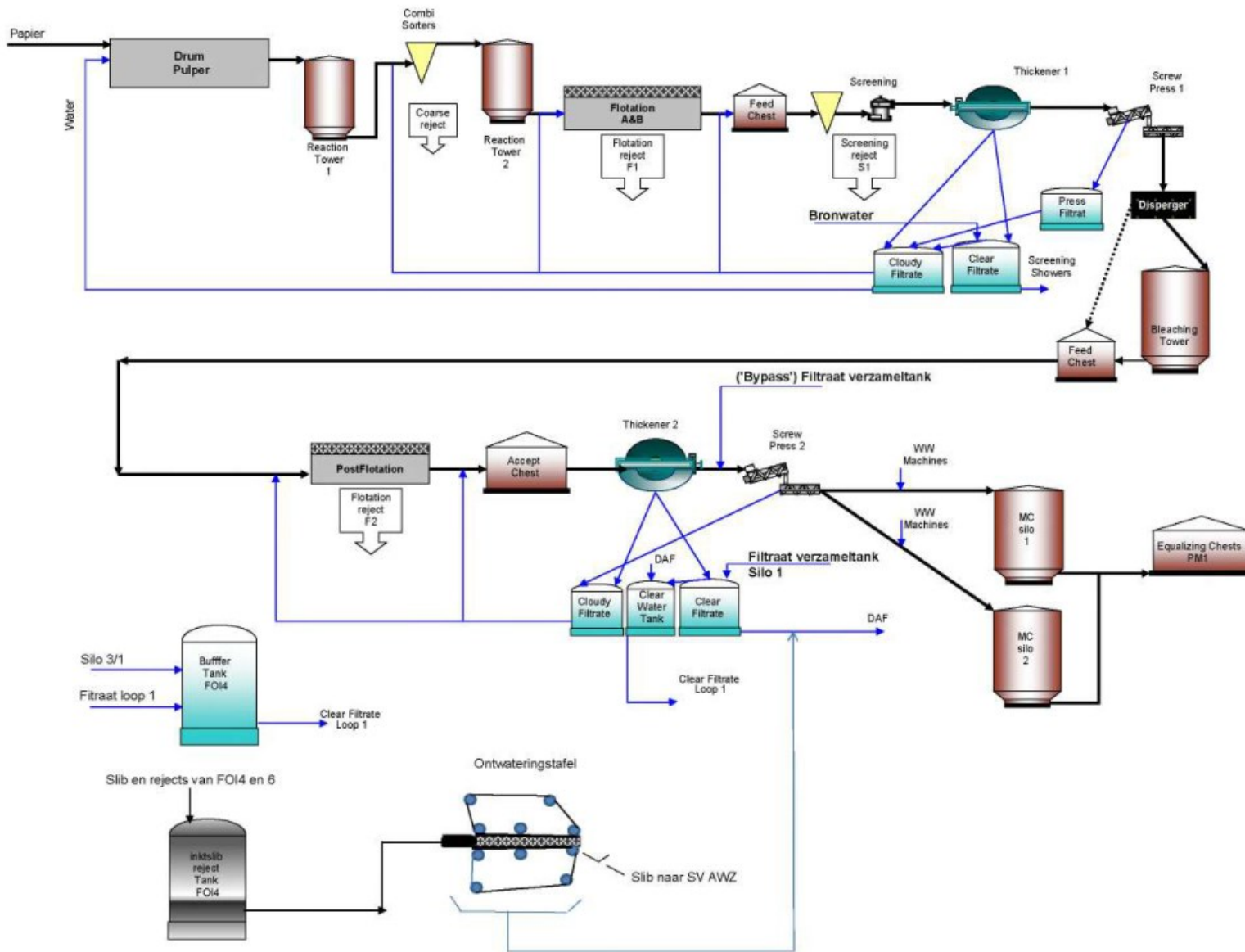

### FOI6 - Simplified Flowsheet

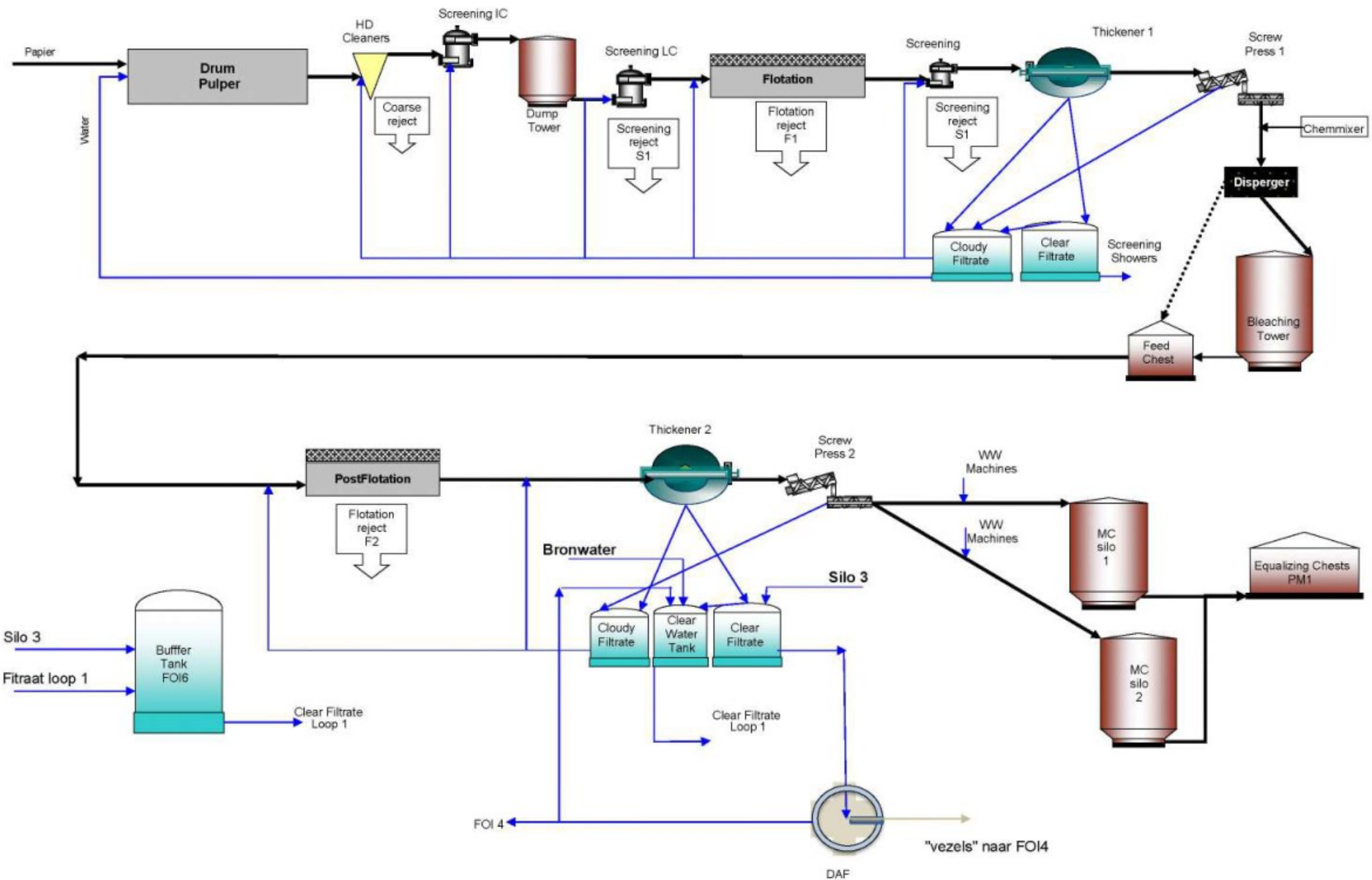

# PM1 - Simplified Flowsheet

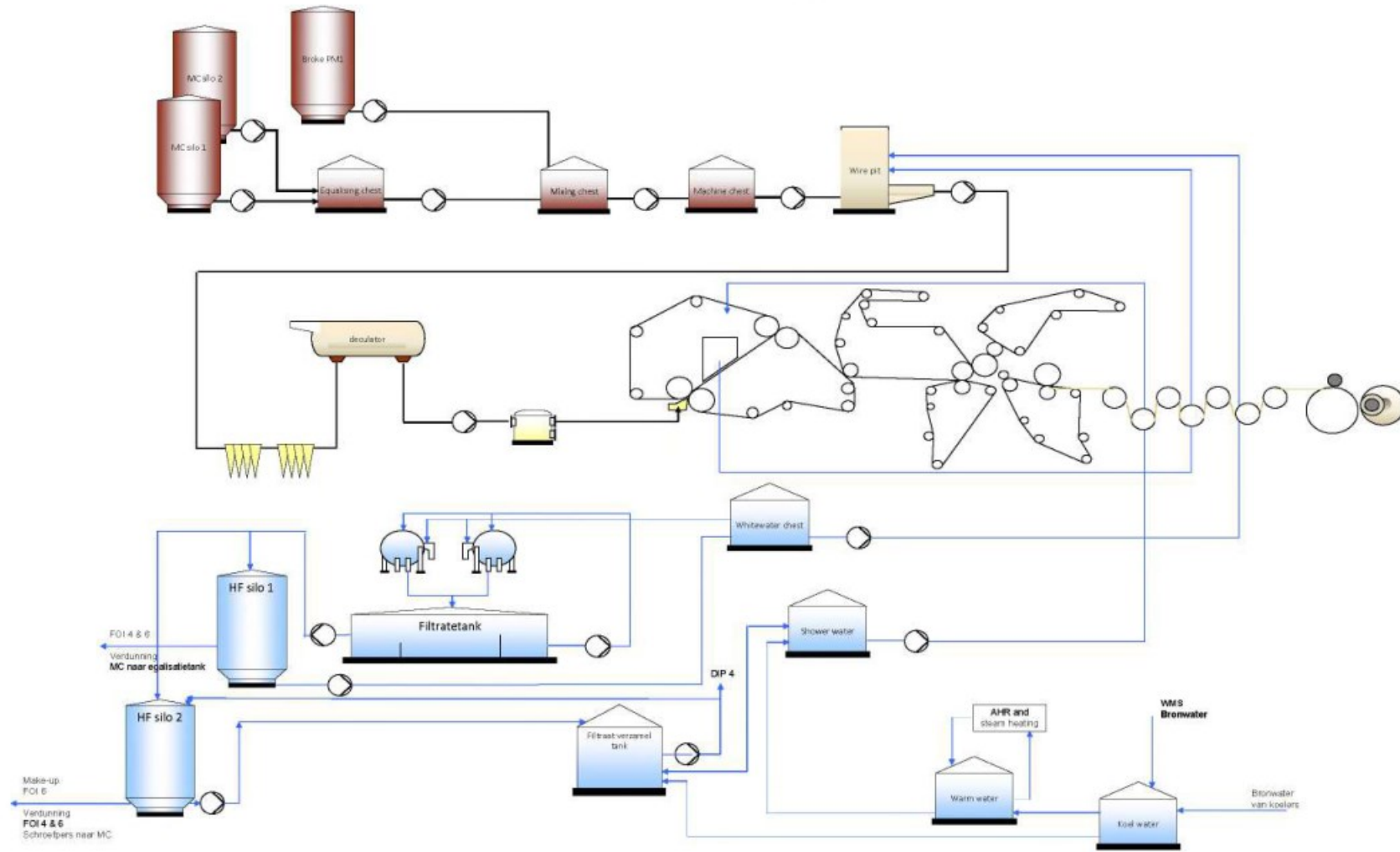

# RCF - Simplified Flowsheet

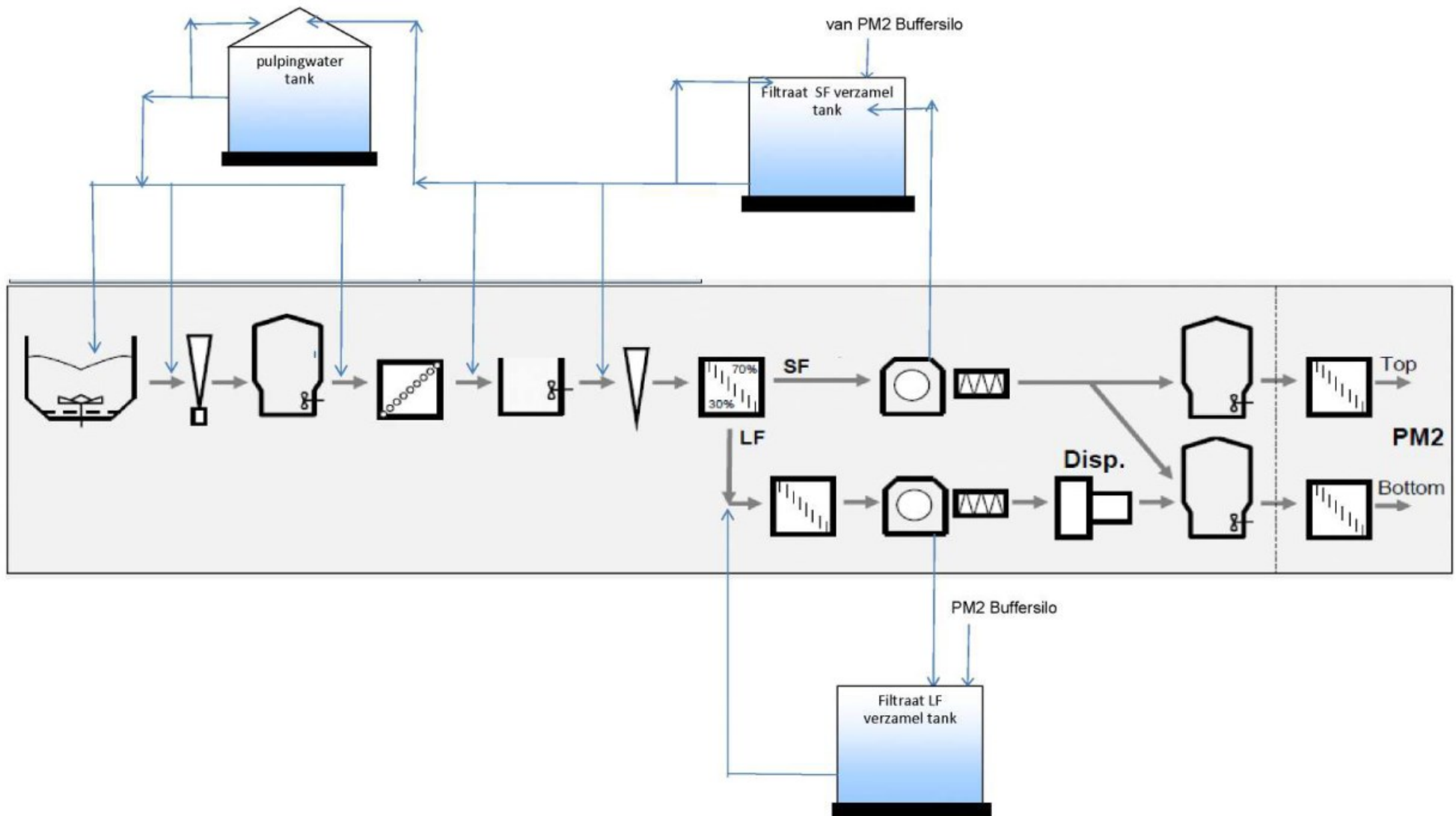



## PM2 - Simplified Flowsheet

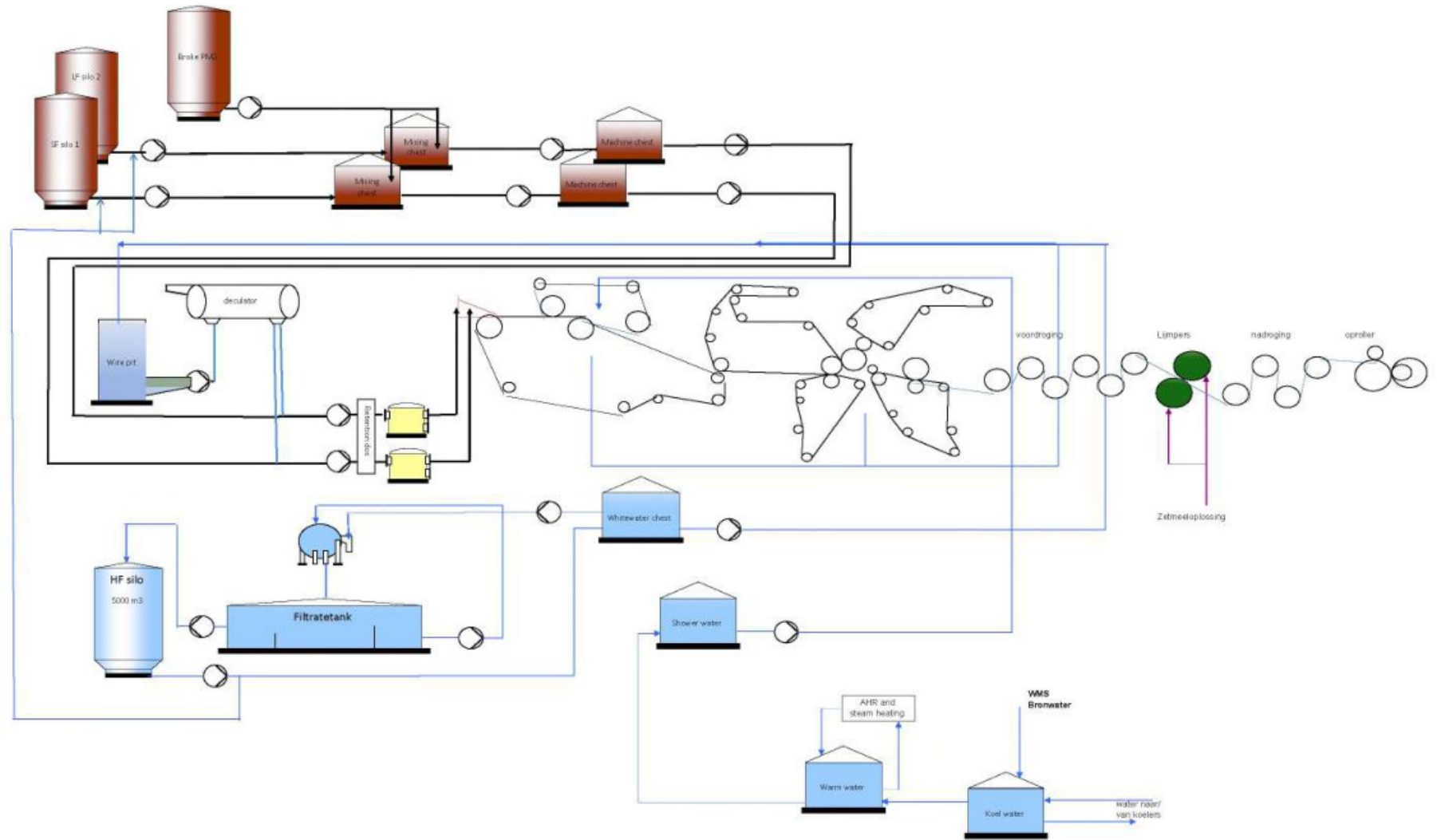

# Centrale - Simplified Flowsheet

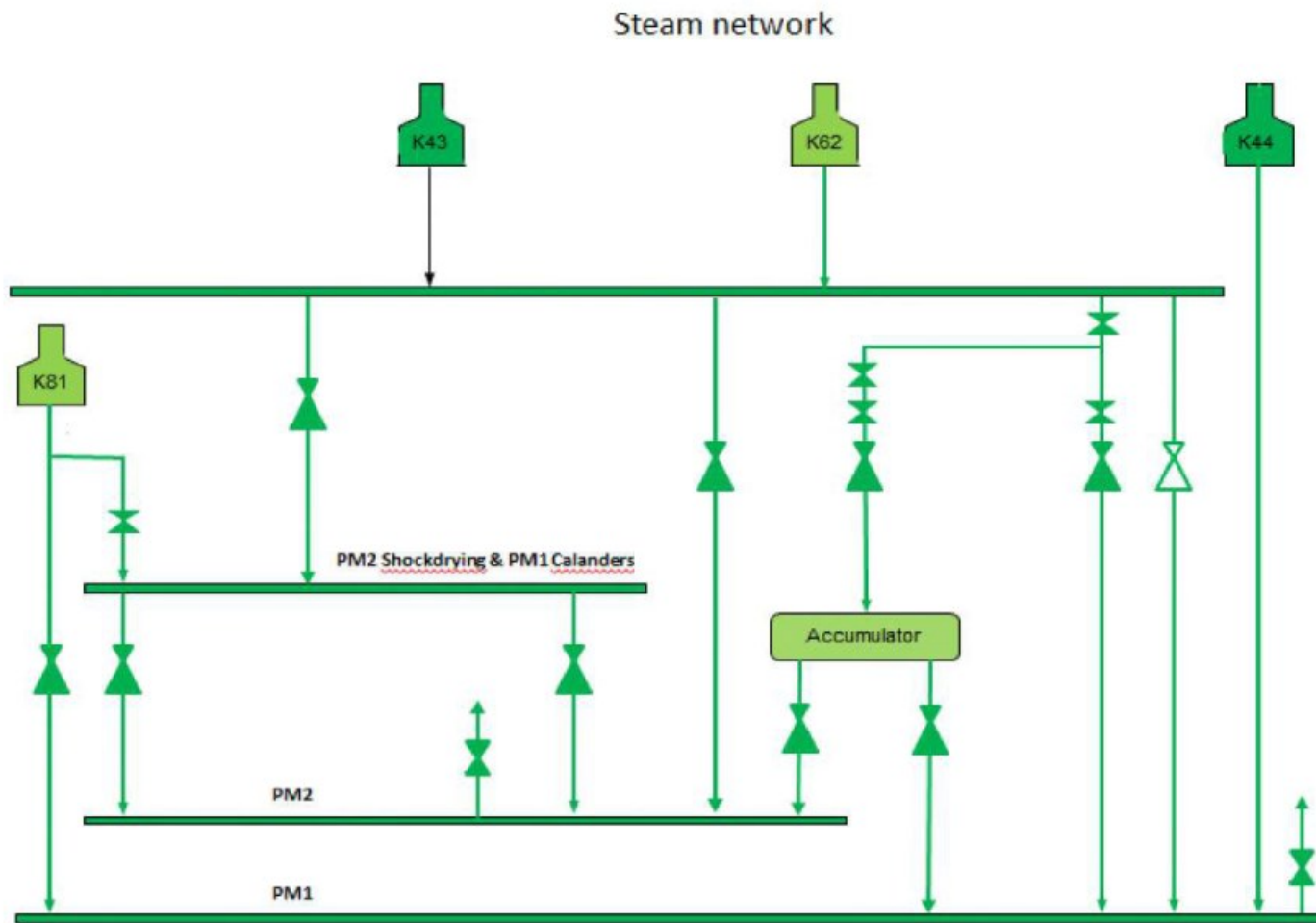

# AWZI - Simplified Flowsheet

